

# High-Speed Fiber-Coupled Si Bias Detectors

1GHz, 400-1000nm



DATASHEET

BUY NOW



## Features

- Low Signal Distortion
- High Bandwidth 1GHz
- Fiber Coupled
- Power Supplier Operation
- Battery Operation
- Fast Response

## Applications

- General Lab Use
- Instruments

The HSDT series High-Speed Fiber-Coupled Detectors feature high fidelity response at high bandwidth >GHz. Biased detectors are the preferred method to measure a signal's fast transit characters, avoiding distortions caused by amplification circuitry. The HSDT fiber-coupled detectors produce a linear response to the incident light. Being reverse-biased with an internal battery, the HSDT is operated in a photoconductive mode in which an input light generates a current flow. The high bandwidth signal is output through an SMA connector for monitoring with an oscilloscope or other measurement electronics. Since the signal is not amplified, a parallel resistor to the output that converts the detector current to an output voltage can maximize the response frequency. The smaller the parallel resistance at the output end is, the higher the peak power of the incident optical signal is required. The HSDT has a 100k parallel resistance built-in to reduce the background noise. For measurement <300MHz, no resistor is needed. For measurement >300MHz, a 50-ohm resistor is required to terminate parallelly at the oscilloscope input. To measure >500ns laser pulse, the detector output needs 1k-10k ohm resistance in parallel.

The HSDT detectors are designed for test or measurement applications, including research in the fields of data communications, analog microwaves, and general high-speed photonics. A wall-pluggable DC power supply is an available option.

## Specifications

Parameter	Min	Typical	Max	Unit
Detector Diameter		250		μm
Wavelength Response	400		1000	nm
Peak Response <sup>[1]</sup>		0.4		A/W
Capacitance		1.7		pF
Rise/Fall Time <sup>[2]</sup>		1		ns
Bandwidth <sup>[3]</sup>			1	GHz
NEP <sup>[1]</sup>		9x10 <sup>-15</sup>		W/Hz <sup>1/2</sup>
Dark Current		0.2		nA
Bias Voltage			12	V
Optical Damage Threshold	20			mW
Operating Temperature	0		50	°C
Optical Input <sup>[4]</sup>		FC/PC		
Electric Output (DC Coupled)		SMA		
Battery		A23, 12V, 40mAh		

### Notes:

- [1]. @730nm
- [2]. 80/20%
- [3]. Defined as the boundary at which the output is 3dB below the normal output
- [4]. Using FC/APC to input light may cause the artificial tail in the measurement profile

**Legal notices:** All product information is believed to be accurate and is subject to change without notice. Information contained herein shall legally bind Agiltron only if it is specifically incorporated into the terms and conditions of a sales agreement. Some specific combinations of options may not be available. The user assumes all risks and liability whatsoever in connection with the use of a product or its application.

Rev 03/13/24

# High-Speed Fiber-Coupled Si Bias Detectors

1GHz, 400-1000nm



## DATASHEET

### Mechanical Dimensions (mm)

#### Spectral Response (typical)

#### Pulse Response (typical)

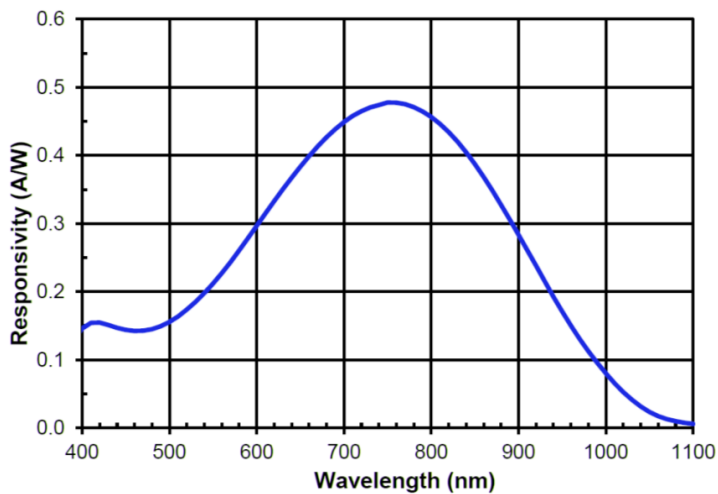

# High-Speed Fiber-Coupled Si Bias Detectors

1GHz, 400-1000nm



## DATASHEET

### Spectral Response

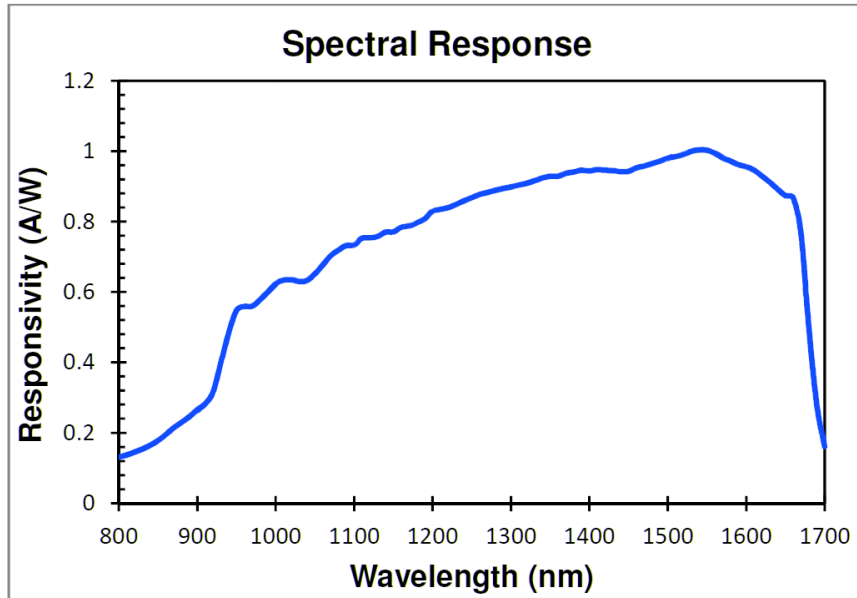

# High-Speed Fiber-Coupled Si Bias Detectors

1GHz, 400-1000nm



## DATASHEET

### Frequency Response (typical)

### Accessories

■ 50 ohm Parallel Resistor

\$25

■ Low Noise Wall Pluggable Power Supply

\$125

### Ordering Information

Prefix	Type	Wavelength	Speed	Configure	Package	Optic Plate	50 ohm	Power Supply
HSDT-	Silicon = S	800-1700nm = 1 Special = 0	4GHz = A4	Regular = 1 Special = 0	Regular = 1 Special = 0	Non = 1 Yes = 2	Non = 1 Yes = 2	Non = 1 Yes = 2

# High-Speed Fiber-Coupled Si Bias Detectors

1GHz, 400-1000nm



DATASHEET

## Operation Manual

- Connect the detector to an oscilloscope with an appropriate parallel resistor at the oscilloscope connection.
- Rotate the battery holder to open and load the battery, then close it.
- Push the back of the battery holder in to switch on
- Couple the optical input into the detector using an FC/PC cable
- The measured optical profile should be displayed on the oscilloscope
- For long operations, connect the DC power supply and push out the switch at the back of the battery holder.

## Operation Physics

The photodiode consists of a PN junction that generates a photocurrent when light with energy (wavelength) matching the semiconductor's band gap illuminates in the region of the junction. In operation, a reverse external bias is applied to enhance the responsibility by increasing the width of the depletion junction and decreasing junction capacitance. The measured output current is linearly proportional to the input optical power. This type of directly biased photodiode is attractive for its fast response with little distortion. It is a challenge to produce high bandwidth photodetector with an amplifier that often distorts the true transit profile of a fast optical signal. Consequently, a biased photodetector without an amplifier is the choice for high-speed measurement. The bandwidth is inversely proportional to the active detector area. The bias voltage also generates a leakage current, called dark current, which increases with temperature. Dark current approximately doubles every 10 °C increase in temperature. Applying a higher bias will decrease the junction capacitance but will also increase the dark current.

Figure 1 illustrates the bias circuitry inside the detector.

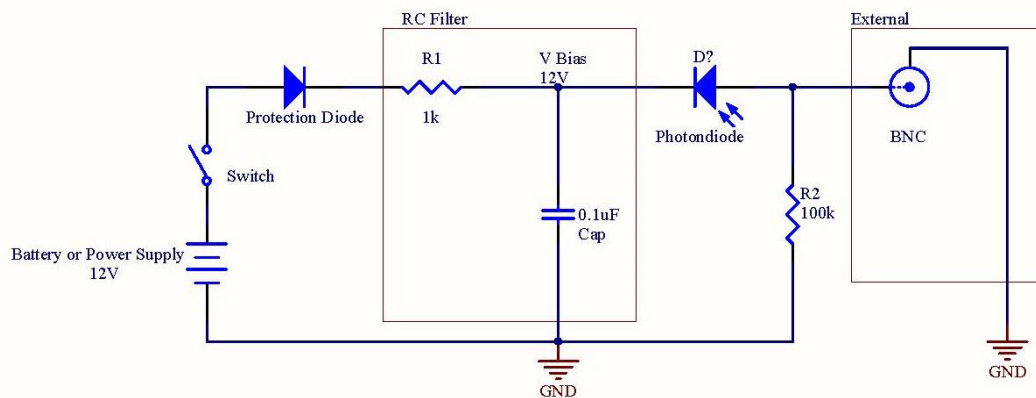

# High-Speed Fiber-Coupled Si Bias Detectors

1GHz, 400-1000nm



DATASHEET

## Application Notes

---

### Fiber Core Alignment

Note that the minimum attenuation for these devices depends on excellent core-to-core alignment when the connectors are mated. This is crucial for shorter wavelengths with smaller fiber core diameters that can increase the loss of many decibels above the specification if they are not perfectly aligned. Different vendors' connectors may not mate well with each other, especially for angled APC.

### Fiber Cleanliness

Fibers with smaller core diameters ( $<5 \mu\text{m}$ ) must be kept extremely clean, contamination at fiber-fiber interfaces, combined with the high optical power density, can lead to significant optical damage. This type of damage usually requires re-polishing or replacement of the connector.

### Maximum Optical Input Power

Due to their small fiber core diameters for short wavelength and high photon energies, the damage thresholds for device is substantially reduced than the common 1550nm fiber. To avoid damage to the exposed fiber end faces and internal components, the optical input power should never exceed 20 mW for wavelengths shorter 650nm. We produce a special version to increase the handling by expanding the core side at the fiber ends.